

Martin® QC1™ Cleaner XHD



The [Martin® QC1™ Cleaner XHD](#) tackles the tough jobs. Designed for rugged conditions, this sturdy cleaner features a one-pin blade change, making replacement of a worn blade a simple procedure.

The Martin® QC1™ Cleaner XHD includes a Spring Tensioner to maintain proper cleaning pressure while minimizing the need for adjustment.

Dual tensioners are supplied with cleaners for belts 48 in. (1219 mm) wide or wider.

NOMENCLATURE

35899- XX XX XX XX X

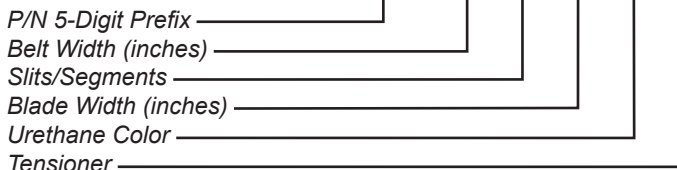

35899D XX XX XX XX X

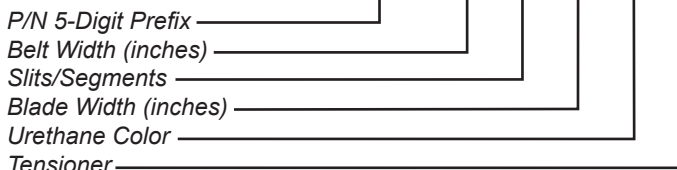

SLITS/SEGMENTS

11 for no slits or segments **10** for segments only
01 for slits only **00** for slits & segments

URETHANE COLOR

BR for Brown **GR** for Green
NB for Navy Blue **CL** for Tan
Blank for Orange

TENSIONER

T for Martin® Spring Tensioner XHD

Example #1: P/N 35899-481O42T is a belt cleaner for a 48-in. wide belt, with segments, standard orange urethane blade. Blade coverage is belt width minus 6 in., with a Spring Tensioner XHD.

Example #2: P/N 35899-600048BR is a belt cleaner for a 60-in. wide belt, with wear slits and segments, brown urethane blade that is 48 in. Blade coverage is belt width minus 12 in., with no tensioner included.

BENEFITS

- **Fast Blade Change Cuts Service Expense**
One-pin blade replacement makes blade replacement a fast and easy operation.
- **Matched Tensioner Maintains Consistent Cleaning**
Martin® QC1™ Cleaner XHD and Spring Tensioner are system-engineered to preserve the cleaning edge from high belt speeds and multiple splices.
- **Curved Blade Provides Consistent Cleaning**
Patented “CARP” (Constant Angle Radial Pressure) design maintains cleaning performance through all stages of blade life.
- **Rugged Construction Suits Tough Conditions**
Mainframe of rugged 3/8-in. (9.5-mm) thick DOM steel tubing has steel bar backbone. Aluminum extrusion in blade base holds cleaner snugly to backbone.
- **Blade Materials Match Application**
Martin Engineering’s urethane expertise provides blades to suit standard, high-temperature, or high-abrasion conditions.
- **The Most Cleaner, the Least Investment**
Economical pre-cleaner and tensioner system combines effective cleaning, durable life, and low-maintenance requirements.

NOTES

Martin® QC1™ Cleaners XHD are available for belts up to 120 in. (3048 mm) wide. For belts wider than 72 in. (2000 mm) a dual-blade assembly is required.

Normal blade length is belt width less 6 in. (150 mm). For belts with a 45° trough or where material is centered on belt, customer should consider a blade that is belt width less 12 in. (300 mm). This is because belt edges may not require cleaning, and blade-to-belt friction in these areas may lead to premature wear of cleaner and/or belt.

Martin® QC1™ Cleaner XHD will mount into existing Martin® DT1 Cleaner XHD locations. Martin® QC1™ Blades XHD will NOT fit onto Martin® DT1 Mainframe XHD.

TECHNICAL DATA SHEET

SPECIFICATIONS & DIMENSIONS – in. (mm)

| Part Number 35899-XXXXXXX (belt width less 6 in.) | | | | | |
|---|-----------------------|----------------------------|----------------------------|--------------------------------|----------------------------------|
| Part Number | Belt Width in (mm) | Dim. A Blade in (mm) | Dim. B Frame in (mm) | Cleaner Ship Wt. lb (kg) | Tensioner Ship Wt. lb (kg) |
| 35899-18XX12 | 18 (457) | 12 (305) | 66 (1676) | 75 (34) | 40 (18) |
| 35899-24XX18 | 24 (610) | 18 (457) | 72 (1829) | 90 (41) | 40 (18) |
| 35899-30XX24 | 30 (762) | 24 (610) | 78 (1981) | 105 (48) | 40 (18) |
| 35899-36XX30 | 36 (915) | 30 (762) | 84 (2134) | 120 (54) | 40 (18) |
| 35899-42XX36 | 42 (1067) | 36 (915) | 90 (2286) | 135 (61) | 40 (18) |
| 35899-48XX42 | 48 (1219) | 42 (1067) | 96 (2438) | 150 (68) | 51 (23)* |
| 35899-54XX48 | 54 (1372) | 48 (1219) | 102 (2590) | 165 (74) | 51 (23)* |
| 35899-60XX54 | 60 (1524) | 54 (1372) | 108 (2743) | 180 (81) | 51 (23)* |
| 35899-66XX60 | 66 (1676) | 60 (1524) | 114 (2896) | 195 (88) | 51 (23)* |
| 35899-72XX66 | 72 (1829) | 66 (1676) | 120 (3048) | 210 (95) | 51 (23)* |
| Part Number 35899-XXXXXXXX (belt width less 12 in.) | | | | | |
| 35899-24XX12 | 24 (610) | 12 (305) | 72 (1829) | 86 (39) | 40 (18) |
| 35899-30XX18 | 30 (762) | 18 (457) | 78 (1981) | 100 (45) | 40 (18) |
| 35899-36XX24 | 36 (915) | 24 (610) | 84 (2134) | 114 (51) | 40 (18) |
| 35899-42XX30 | 42 (1067) | 30 (762) | 90 (2286) | 128 (58) | 40 (18) |
| 35899-48XX36 | 48 (1219) | 36 (915) | 96 (2438) | 143 (64) | 40 (18) |
| 35899-54XX42 | 54 (1372) | 42 (1067) | 102 (2590) | 158 (71) | 51 (23)* |
| 35899-60XX48 | 60 (1524) | 48 (1219) | 108 (2743) | 173 (78) | 51 (23)* |
| 35899-66XX54 | 66 (1676) | 54 (1372) | 114 (2896) | 188 (85) | 51 (23)* |
| 35899-72XX60 | 72 (1829) | 60 (1524) | 120 (3048) | 203 (92) | 51 (23)* |

For belt widths above 72 in. (2000 mm) contact Martin Engineering.

* Requires dual tensioners P/N 38003-2

Martin® QC1™ Cleaner XHD
P/N 35899-XXXXXXXXXX

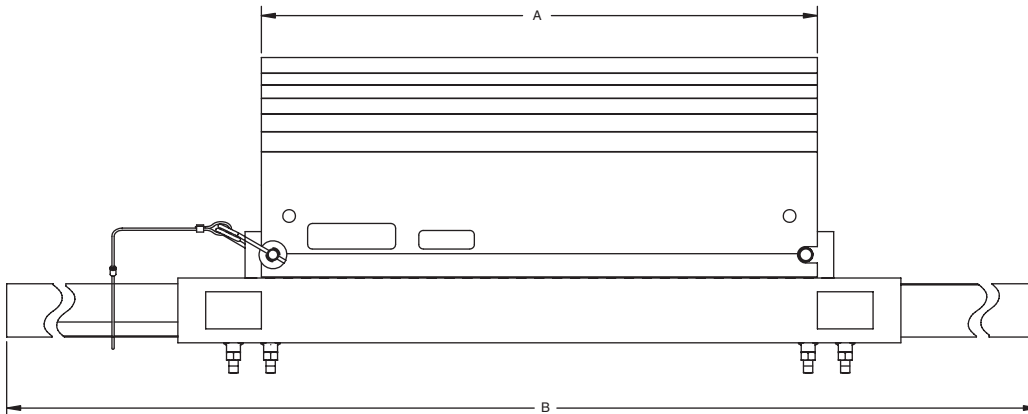

Spring Tensioner XHD
P/N 38003

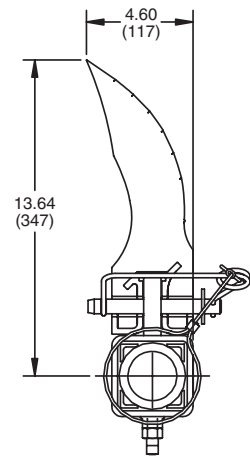
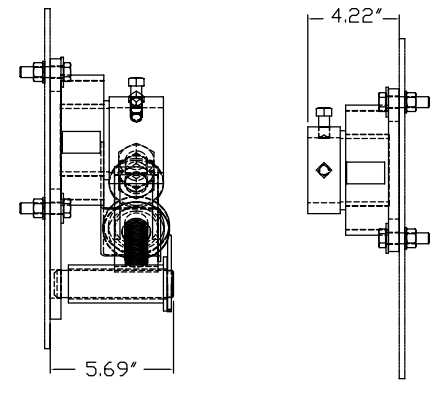
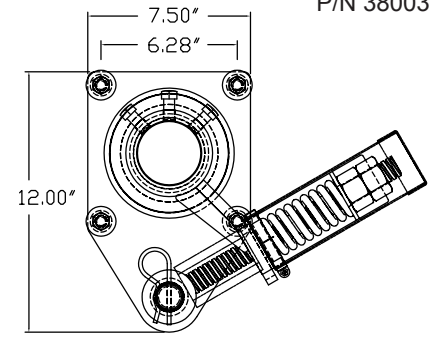

TECHNICAL DATA SHEET

INSTALLATION AND MOUNTING

Installation Recommendations:

| | |
|----------------------|-------------------------------------|
| Head Pulley Diameter | 24 in. – 30 in. (609.6 – 762 mm) |
| Maximum Belt Speed | 1200 fpm (6 m/s) |

Mounting Location:

| Head Pulley Diameter* | Mounting Dimension |
|-----------------------|--------------------|
| 16 in. (400 mm) | 5.75 (146) |
| 20 in. (500 mm) | 5.50 (140) |
| 24 in. (600 mm) | 5.25 (133) |
| 28 in. (700 mm) | 5.00 (127) |
| 30 in. (750 mm) | 4.75 (120) |

* includes belt and lagging

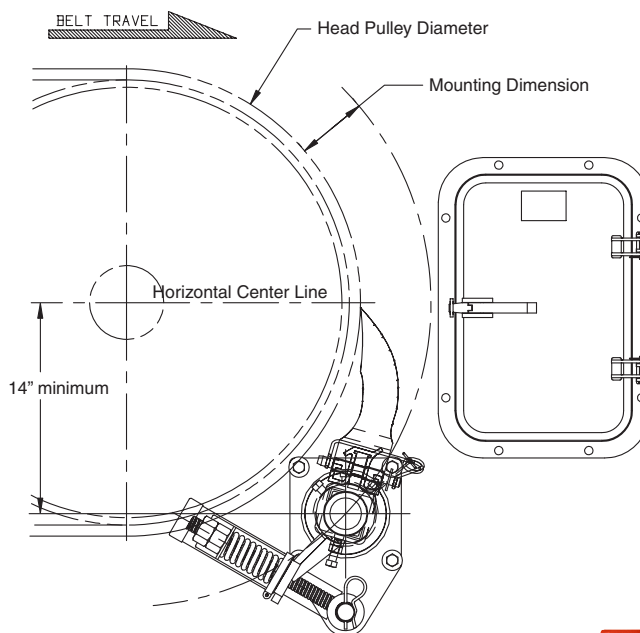

TENSIONER OPTIONS

| Tensioner | P/N | Blade Width |
|-----------------------------------|----------|-----------------------------|
| Martin® Spring Tensioner XHD | 38003 | 36 in. (915 mm) or less |
| Martin® Spring Tensioner XHD Dual | 38003-2 | 42 in. (1067 mm) or greater |
| Martin® Air Tensioner XHD | 32135 | 42 in. (1067 mm) or less |
| Martin® Air Tensioner XHD Dual | 32135-2R | 48 in. (1372 mm) or greater |

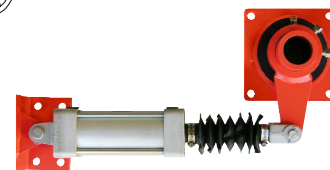

REPLACEMENT PARTS

| Item | P/N | P/N Nomenclature | Urethane Options |
|--------------------------|---|--------------------------------------|------------------|
| Blade—72" blades & below | 35897- XX X XX XX | XX = belt width in inches | OR = Orange |
| Blade—72" blades & above | 35897D XXXXXX L or 35897D XXXXXX R | X = option for slits | CL = Tan |
| | | X = option for segments | NB = Navy Blue |
| | | XX = blade width in inches | BR = Brown |
| | | XX = blade color and material | GR = Green |

Note: 72" (1,829 mm) cleaners can come with one 60" or 66" long blade or two 33" blades (right & left)
84" (2,134 mm) and larger cleaners always have dual blades (right & left)

FREQUENTLY ASKED QUESTIONS

My Pre-Cleaner keeps flipping through. What is wrong?
The mounting location may be too far away from the belt. Relocate to the proper mounting location. Replace the mainframe or end weldments if they are bent. Check set screws to determine if they are tight. Retighten if necessary.

My Pre-Cleaner is wearing more in the center of the blade.
The blade is too wide for this application. Replace with a shorter length blade.

ACCESSORIES

| PART | P/N |
|-----------------------------------|----------|
| Martin® Steel Inspection Door | CYA-1218 |
| Martin® Hanger Mount XHD Assembly | 27382-SL |



Martin Engineering USA
One Martin Place
Neponset, IL 61345-9766 USA
800 544 2947 or 309 852 2384
Fax 800 814 1553
www.martin-eng.com

**COMPANY WITH
QUALITY SYSTEM
CERTIFIED BY DNV
= ISO 9001:2008 =**

Problem Solved™

Form No. L3501-08/12
© Martin Engineering Company 2008, 2012